

Operating Instructions

Household Use

Electronic Rice Cooker

Thank you for purchasing the Panasonic product.

- This product is intended for household use only.
- Please read these instructions carefully and follow safety precautions when using this product.
- Before using this product **please give your special attention to “Safety Precautions” (Page 2~3).**
- Please retain a copy of your proof of purchase and keep it with these operating instructions.

Reserve it for later use

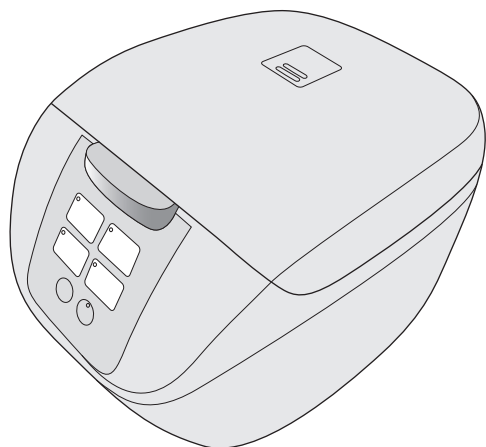

Model No. 1.0L Model **SR-DF101**
1.8L Model **SR-DF181**

Table of Contents

Before use

Safety Precautions	2~3
Parts identification	4
• Control panel	4
• Entire unit	4

Usage

Preparations	5
Functions	6
• Quick Cook/Steam	6
• White Rice • Keep Warm	7
• Brown Rice	8
• Porridge/Soup	9
Recipes	10~11
Cleaning and maintenance	12

In Trouble

Troubleshooting	13
Specifications	13

Safety Precautions

Must be followed!

In order to prevent accidents or injuries to the users, other people, and damage to property, please follow the instructions below.

■ The following charts indicate the degree of damage caused by wrong operation.



Warning: Indicates serious injury or death.



Caution: Indicates risk of injury or property damage.

■ The symbols are classified and explained as follows.



These symbols indicate prohibition.



This symbol indicates requirement that must be followed.

Warning

■ Do not use the appliance if the power cord or power plug is damaged or the power plug is loosely connected to the power outlet.

 (It may cause an electric shock, short circuit or fire.)

■ Do not insert any objects in the vent or gaps.

 Especially metal objects such as pins or wires. (It may cause an electric shock or malfunction.)

■ This appliance is not intended for use by persons (including children) with reduced physical, sensory or mental capabilities, or lack of experience and knowledge, unless they have been given supervision or instruction concerning use of the appliance by a person responsible for their safety. Children should be supervised to ensure that they do not play with the appliance.

 (It may cause burn or injury.)

■ Clean the power plug regularly.

 (A soiled power plug may cause insufficient insulation due to the moisture, and may cause a fire.)

• Unplug the power plug, and wipe with a dry cloth.

■ Do not damage the power cord or power plug.

 Following actions are strictly prohibited.

Modifying, placing near heating elements, bending, twisting, pulling, putting heavy objects on top, and bundling the cord (It may cause an electric shock, short circuit or fire.)

• If the supply cord is damaged, it must be replaced by the manufacturer, its service agent or similarly qualified persons in order to avoid a hazard.

■ Do not immerse the appliance in water or splash it with water.

 (It may cause a short circuit or electric shock.)

• Please enquire with an authorised dealer if water gets inside the appliance.

■ Use only a power outlet rated at 10 amperes and alternating electric current at 240 volts.

 (Plugging other devices into the same outlet may cause electric overheating, which may cause a fire.)

• Use only an extended cord rated at 10 amperes minimum.

■ Discontinue using the appliance immediately and unplug the power connector in cases of abnormal situations and breaking down.

 (It may cause smoking, a fire, or electric shock.)

(e.g. for abnormal situations or breaking down)

- The power plug and the power cord become abnormally hot.
- The power cord is damaged or power failure occurs when is touched.
- The main body is deformed or abnormally hot.
- The unit gives out smoke or scorching smell.
- There are cracks, looseness or wobbles of the appliance.
- The heating plate is warped or the pan is deformed.

→Please make enquiries at Panasonic authorized service center for inspection and repair immediately.

■ Do not plug or unplug the power plug with wet hands.

 (It may cause an electric shock.)

■ Do not get your face close to the steam vent or touch it with your hand. Keep the steam vent out of reach of small children.



Steam vent
(It may cause a burn.)

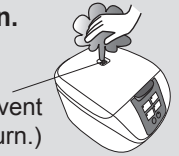

■ Do not modify, disassemble, or repair this appliance.

 (It may cause a fire, electric shock or injury.)

• Please make enquiries at the store or the repair department of an authorised dealer.

■ Insert the power plug firmly.

 (Otherwise it may cause an electric shock and fire caused by the heat that may generate around the power plug.)

• Do not use a broken power plug or a loose power outlet.

Safety Precautions

Must be followed!

⚠ Caution

■ Do not use the appliance on following places.

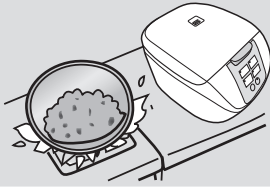

- The place where it may be splashed with water or near a heat source.
- The place with an uneven surface or on non-heat-resistant carpet.
- Near a wall or furniture. (It may cause a discoloration or deformation.)

■ Do not touch heating elements while the appliance is in use or after cooking.



Especially the heating plate (It may cause a burn.)

■ Do not expose the power plug to steam.



- Do not expose the power plug to steam when it is plugged in. (It may cause a short circuit or fire.)
- When using a cabinet with sliding table, use the appliance where the power plug cannot be exposed to steam.

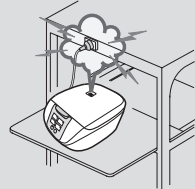

■ Do not touch the hook button while moving the appliance.



(It may cause the outer lid to open, resulting in a burn.)

■ Be sure to hold the power plug when unplugging the power plug.



(Otherwise it may cause an electric shock, short circuit, resulting in fire.)

■ Do not use the cord set (for instrument plug and power plug) that is not specified for use with this appliance. Also do not transfer them.



(It may cause an electric shock, leak, and fire.)

■ Do not open the outer lid while cooking.



(It may cause a burn.)

■ Unplug the power plug from the power outlet when the appliance is not in use.



(Otherwise it may cause an electric shock and fire caused by a short circuit due to the insulation deterioration.)

■ Please allow the appliance to cool down before cleaning it.



(Touching hot elements may cause a burn.)

■ Do not use other pans than the one specified.



(It may cause a burn and injury due to overheat or malfunction.)

Precautions for Use

Please put in correct amount of rice and water and select functions correctly according to the operating instructions.

(So as to avoid overflow of rice water, half-cooked rice or scorched rice.)

Do not put ingredients to be cooked directly into the appliance in which no pan is placed.

(So as to prevent any impurities from causing failure.)

Do not use the appliance on any heat labile object such as carpet, electric heating carpet and tablecloth (made of vinyl plastics), etc.

(So as to avoid poor cooking or fire.)

Before using the appliance, remove the protective bag on the pan and the anti-tarnish paper between the pan and the cast heater.

(So as to avoid poor cooking or fire.)

Do not cover the outer lid with cloth or other objects when the appliance is in use.

(So as to avoid deformation, colour change of the outer lid or failure.)

Avoid using the appliance under direct sunlight.

(So as to avoid colour change.)

Do not serve out rice with any metal object.

(So as to avoid scratching the pan coating and causing peeling of the coating.)

Please always clean the foreign objects such as rice on the pan, cast heater and temperature sensor.

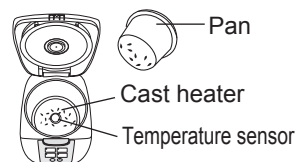

- Do not tilt or overturn the appliance.
- Before cleaning, turn off the power switch and pull out the power plug.

When there is any overflow of rice water from the steam vent, pull out the power plug immediately to disconnect the power supply. Do not resume the use until the rice water on the power plug and the instrument plug is cleaned with a dry cloth.

The appliance is for household use only. Do not use it for any commercial or industrial purposes or any purposes other than cooking.

When power failure occurs during the operation of the appliance, the cooking result may be affected.

Parts identification

Control panel

Press this button for quick cooking or steam cooking.

Press this button for cooking of brown rice.

Press this button to cancel the previous operation or stop keep warm function.

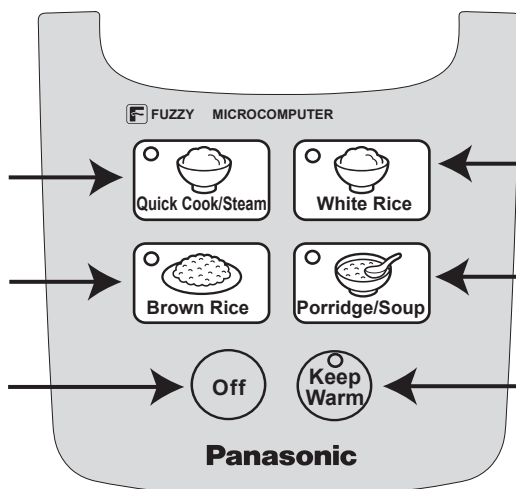

Press this button for cooking of rice.

Press this button for cooking of porridge or soup.

Press this button for keep warm function.

※ This rice cooker has no touch sound or end sound.

Entire unit

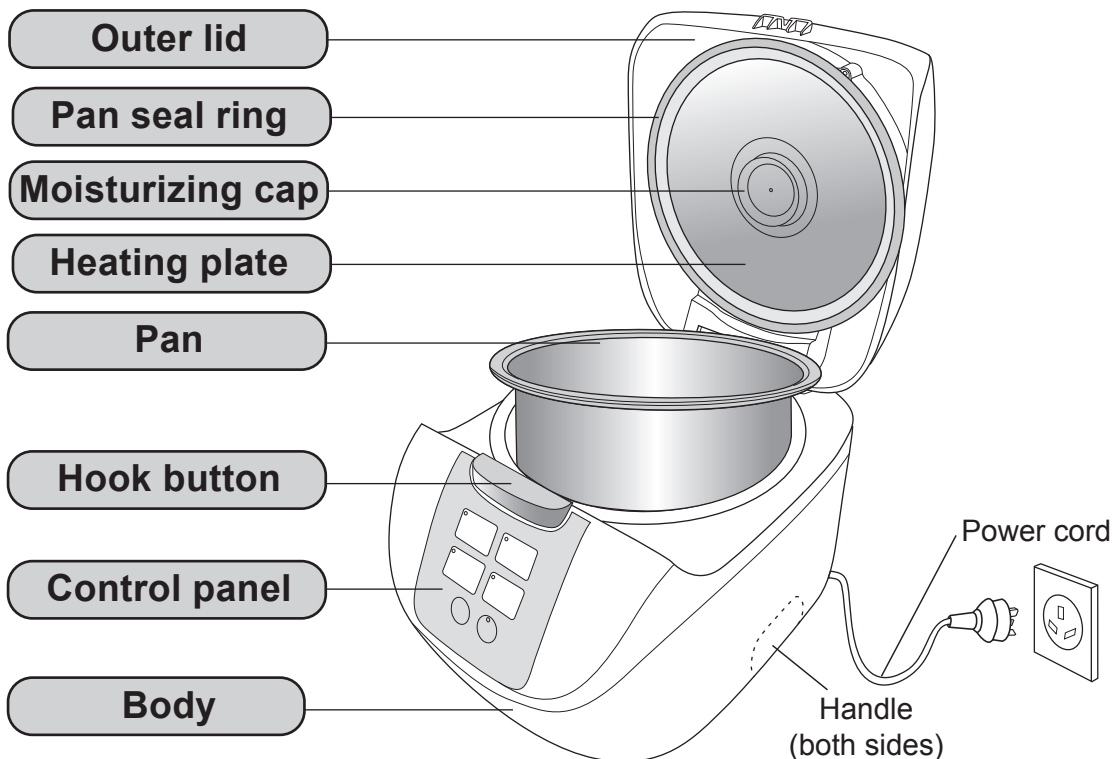

Accessories

※ Please clean the accessories before using.

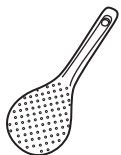

Rice scoop (1)



Measuring cup (about 180 mL) (1)

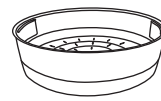

Steaming basket (1)

Preparations

1 Measure rice with the measuring cup provided

- The volume of the measuring cup is about 180 mL (150 g).
- Maximum quantity of rice to be cooked at once P13.
- When using 1.8 L Model for quick cooking of rice or cooking of long-shaped rice, please keep the maximum quantity of rice within 8 cups.

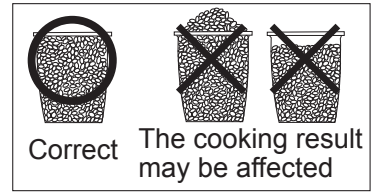

2 Wash the rice till the water turns relatively clear

- ① Wash the rice quickly with plenty of water and stirring the rice lightly to wash it while changing water.
- ② Repeat for several times [wash the rice→pour out water], till the water turns relatively clear.

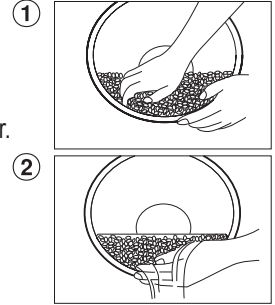

Attentions

- In order to avoid scratching the non-stick coating on the pan surface, do not wash rice in the pan.
- Wash the rice thoroughly. Otherwise, rice crust may appear and the residual rice bran may affect the taste of the rice.

3 Place the washed rice into the pan

Add water until the corresponding waterline and dry the outside of the pan.

- When adding water, pay attention to the scales at both sides and keep them at the same height.
- When stewing soup, the total volume of ingredients and water shall not exceed the maximum waterline for "PORRIDGE".
- When cooking mixed rice or glutinous rice, please add water according to the following table.

Rice quantity (measuring cups)	Water quantity (measuring cup provided)			
	Mixed rice		Glutinous rice	
	1.0 L Model	1.8 L Model	1.0 L Model	1.8 L Model
1	1 1/2	1 1/2	1 1/4	1 1/4
2	2 3/4	2 3/4	2	2
3	4	4	3	3
4	---	5	---	4
5	---	6 1/4	---	5

※The above water quantities can be increased or decreased according to personal preference.

<Example> When the rice quantity is 6 measuring cups, wash the rice and put into the pan, then add water into the pan till the water surface reaches scale "6" at waterline of "WHITE RICE".

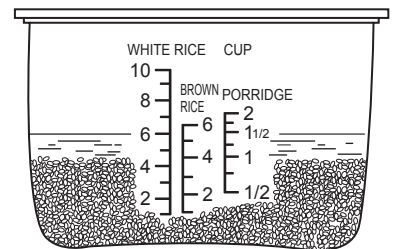

(Example: 1.8 L Model)

4 Put the pan into the body and close the outer lid

- In order that the pan bottom can be closely attached to the cast heater, please rotate the pan along the direction indicated by the arrow for 2 or 3 times.
- Please check whether the moisturizing cap is correctly positioned. (P12)
- When closing the outer lid, please confirm that there is a "click" sound.

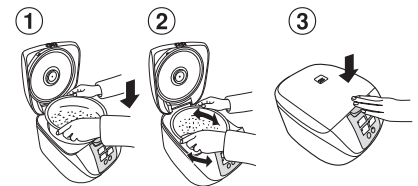

5 Connect the plugs

- Please connect the instrument plug to the body first and then connect the power plug. Make sure that both plugs are firmly connected.

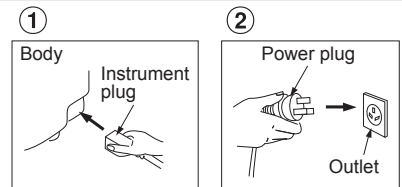

Attentions

- * When using the steaming basket while cooking rice, please refer to the table on the right for the maximum cooking volumes.

Maximum cooking volume (measuring cup provided)

Model No.	1.0 L Model	1.8 L Model
Maximum cooking volume	2	5

Functions Quick Cook/Steam

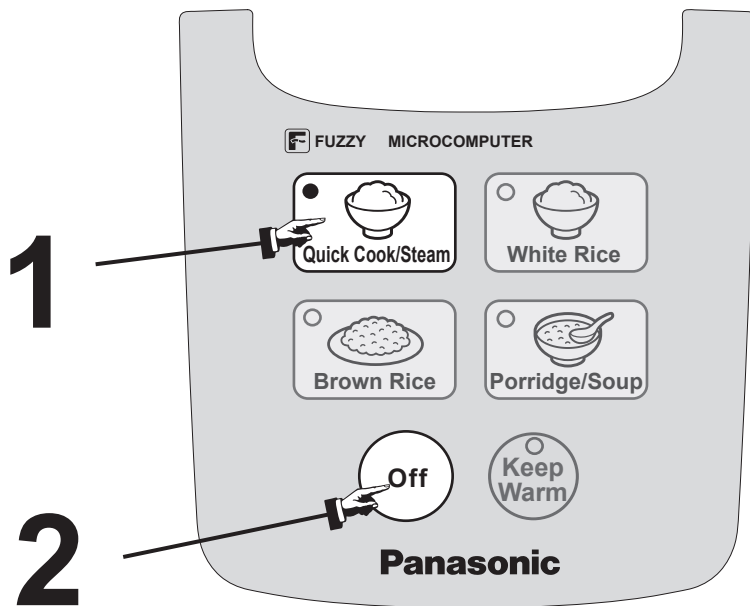

Kind reminder

- When steaming food at same time as cooking rice, please select [White Rice] function.
- The time of steam shall be determined according to the water quantity in the pan. Please adjust the water quantity according to the time required.
- After the water gets boiled and fully evaporated, the rice cooker will turn to the keep warm function automatically.
- If you want to stop steam function during cooking, press [Off] button.
- [Quick Cook/Steam] button can be used for quick cooking rice, please refer to P7 [White Rice] for detailed operations. As the cooking time is shortened, the rice may be harder or there may be rice crust.

Operations (For example: steam with [Quick Cook/Steam] function)

- Add a proper quantity of water (refer to the following table).
- Put the steaming basket into the pan.
- Put the foods to be steamed into the steaming basket.
- Close the outer lid.

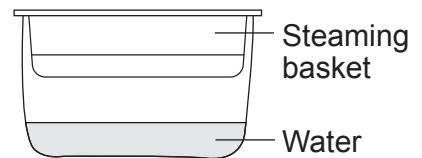

1 Press [Quick Cook/Steam] button

- The indicator for [Quick Cook/Steam] lights up and the steaming starts.

◆ The indicator lights up



Table of steaming time and water quantity. The entire duration from the start to the end refers to the time shown in the following table.

Water quantity (approx.)	1/2 Measuring cup	1 Measuring cup	2 Measuring cups	3 Measuring cups
Steaming time (approx.)	15 Minutes	30 Minutes	50 Minutes	65 Minutes

* The maximum time of steaming is about 70 minutes. When the time is up, no matter the water is completely evaporated or not, the rice cooker will turn to keep warm function automatically.

The cooking is over

- After the water in the pan gets boiled and fully evaporated, the steaming function is ended and the rice cooker will turn to keep warm function automatically.

2 Press [Off] button

- No alarm will sound when the cooking process is finished.
- At this time, the steaming basket is very hot. Please be careful when taking it out.

◆ The indicator lights up The indicator turns off



Functions White Rice • Keep Warm

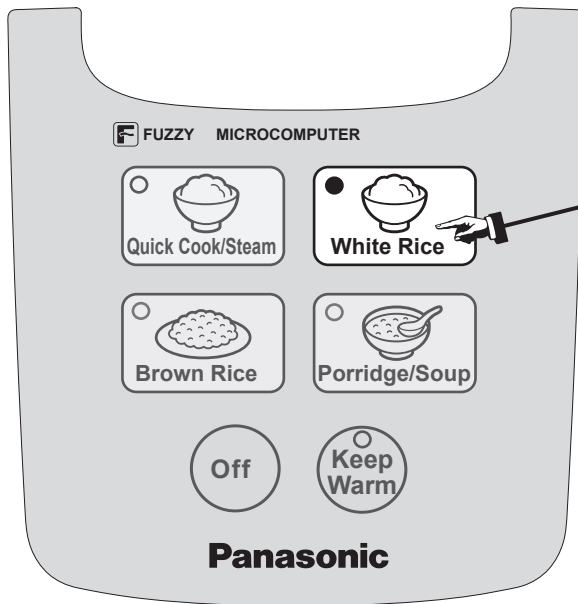

Kind reminder

- When cooking mixed rice or glutinous rice, please select [White Rice] function. For water quantity, please refer to P5.
- Rice cooked with [White Rice] function can be softer and has a better taste.

Operations (For example: cook rice with [White Rice] function)

1 Press [White Rice] button

- The indicator for [White Rice] lights up and the cooking starts.

◆ The indicator lights up



■ Cooking time (reference)

Quick Cook	About 30 minutes
White Rice	About 38 minutes

- The reference time required for cooking at the voltage of 240 V, the room temperature of 20°C, the water temperature of 18°C and the medium rice quantity refers to the time listed in the left table. (1.0 L Model: 3 cups, 1.8 L model: 5 cups)
- The cooking time may vary slightly according to different voltages, room temperatures, water temperatures, water quantities, rice quantities and rice qualities.
- The cooking time of mixed rice or glutinous rice may vary because of the different ingredients added into the rice.

The cooking is over

Loosen the rice

- When the cooking process is over, the rice cooker will turn to keep warm function automatically. To prevent the rice from sticking together, please loosen the rice after cooking.
- No alarm will sound when the cooking process is finished.

◆ The indicator lights up



Keep Warm

- When the cooking process is over, all functions will turn to keep warm function automatically. But some functions are not recommended to use keep warm function, when the cooking process is over, please press [Off] button after cooking.
- You can enjoy the rice within 5 hours in keep warm function, so as not to affect the taste or cause strange smell.
- When in keep warm function, there may be some droplets at the edge of the pan.
- The rice taste may be affected if the rice scoop is left in the rice cooker when the rice is in keep warm function.

Menu	Keep warm	The result after kept warm
Quick Cook, White Rice, Soup	○	
Brown Rice, Mixed rice, Glutinous rice	×	Affects the taste or may cause a strange smell
Porridge	×	Porridge from thickening

Functions Brown Rice

1

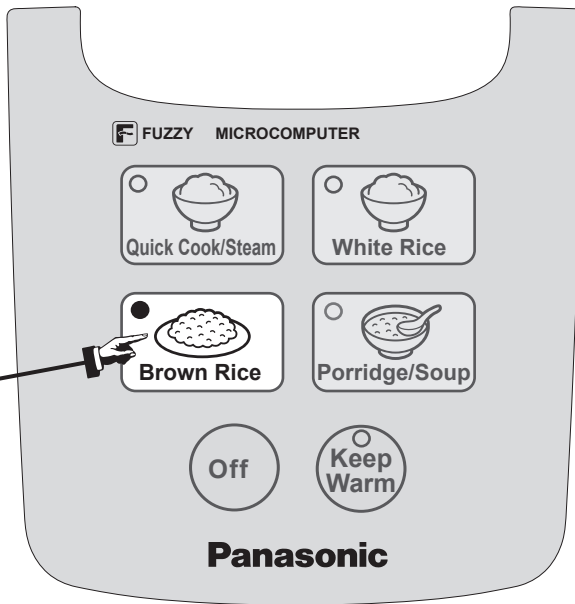

Kind reminder

- Do not use keep warm function for brown rice, so as not to affect the taste.
- Brown rice is a kind of rice which is difficult to cook. In the course of cooking, the rice shall be soaked for about 1 hour first, so that the rice grains can absorb enough water to achieve a satisfactory cooking effect.

Operations (For example: cook rice with [Brown Rice] function)

1 Press [Brown Rice] button

- The indicator for [Brown Rice] lights up and the cooking starts.

◆ The indicator lights up

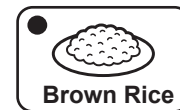

■ Cooking time (reference)

Brown rice	About 1 hour and 50 minutes
------------	-----------------------------

- The reference time required for cooking at the voltage of 240 V, the room temperature of 20°C, the water temperature of 18°C and the medium rice quantity refers to the time listed in the left table. (1.0 L Model: 2 cups, 1.8 L model: 3 cups)
- The cooking time may vary slightly according to different voltages, room temperatures, water temperatures, water quantities, rice quantities and rice qualities.

The cooking is over

Loosen the rice

- When the cooking process is over, the rice cooker will turn to keep warm function automatically. However keep warm function is not recommended, to prevent affecting the taste press [Off] button after cooking.
- No alarm will sound when the cooking process is finished.

◆ The indicator lights up



The indicator turns off



Functions Porridge/Soup

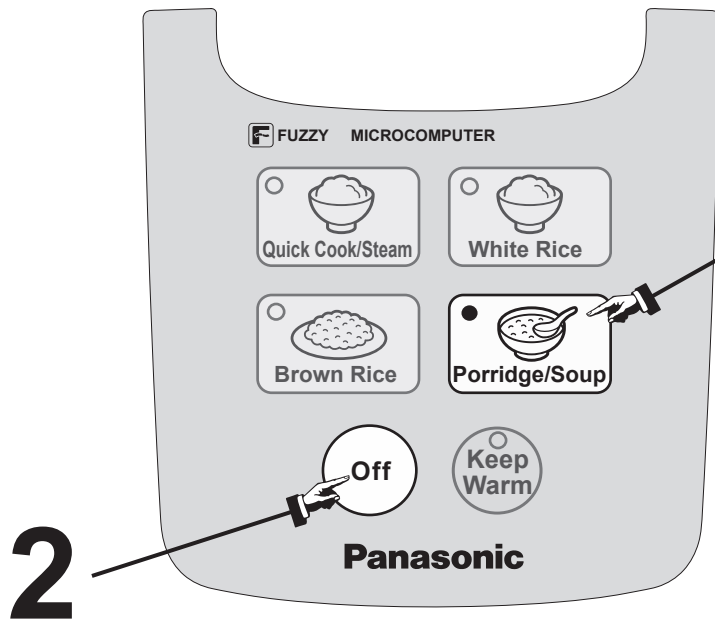

Kind reminder

- Incorrect water quantity or rice quantity may lead to overflow of rice water from the steam vent.
- When the outer lid is opened in cooking, the amount of moisture condensation may be increased.
- When the porridge is kept in keep warm function for an excessively long time, it will get thicker.
- Each time after use, take off and clean the moisturizing cap so as to prevent any strange smell.

Operations (For example: cook porridge with [Porridge/Soup] function)

1 Press [Porridge/Soup] button

- The indicator for [Porridge/Soup] lights up and the cooking starts.
 - Reference cooking time (approx.): 1 hour and 30 minutes.
- ※ When the maximum cooking volume of soup (ingredients and water) exceeds the maximum waterline for "PORRIDGE", overflow or half-cooked soup may occur. (Refer to P13 for specifications)

◆ The indicator lights up



The cooking is over

2 Press [Off] button

- After the cooking process is over, the rice cooker will turn to keep warm function automatically. However keep warm function is not recommended, to prevent affecting the taste press [Off] button after cooking.
- No alarm will sound when the cooking process is finished.

◆ The indicator lights up



The indicator turns off



Recipes

- Caution:**
- Because of the different ingredients added into the rice, there may be scorched rice at the bottom.
 - In this recipe, the cooking volume is for 1.8 L Model. Please refer to the specifications listed on  P13 for cooking volumes for 1.0 L Model.
 - 1 cup (measuring cup): about 150 g.

Mixed Chicken Rice

Ingredients:

Rice	3 measuring cups
Water	4 measuring cups
Chicken	80 g, chopped into small pieces
Burdock	35 g, sliced
Mushroom	2 pieces, after soaking in water, remove the base and shred into strips
Fried bean curd	2 pieces, pour with hot water to remove grease and then shred into strips
Carrot	40 g, shredded into strips

Seasoning:

Cooking wine, soy sauce	20 mL each
Salt	3 g

Cooking method:

- 1) Boil the chicken and burdock in hot water quickly and drain them immediately.
- 2) Wash the rice, put into the pan and add 4 measuring cups of water.
- 3) Pour the seasoning into the pan, stir and put the remaining ingredients in. Close the outer lid.
- 4) Press [White Rice] button to start cooking. When the cooking process is over, you can enjoy the meal.

Corn and Rib Soup

Ingredients:

Ribs	500 g, chopped into 5cm pieces
Corn	2, about 450 g, cut into 5cm pieces
Water	5 measuring cups

Seasoning:

Salt	6.5 g
------	-------

Cooking method:

- 1) Put the ribs into boiling water to remove residual blood and drain them for later use.
- 2) Put all ingredients into the pan, add salt and close the outer lid.
- 3) Press [Porridge/Soup] button, and the cooking process will end after about 1 hour and 30 minutes. (Other seasoning such as chicken powder can be added according to personal preference.)

Recipes

Dim Sum (frozen)

Ingredients:

- | | |
|------------------|---------------------------|
| (A) Small pieces | (B) Big pieces |
| Shrimp dumplings | Steamed BBQ pork buns |
| Sumai | Steamed buns |
| | Sticky rice in lotus leaf |

Cooking method:

- 1) Defrosting is not required. Just put the frozen Dim Sum on the steaming basket and spray some water on the surface of Dim Sum.
- 2) Add 1/2 measuring cup of cold water into the pan.
- 3) Put the steaming basket into the pan and close the outer lid.
- 4) Press [Quick Cook/Steam] button, wait for about 10 minutes and then press [Off] button.

Mung Bean and Liliun Porridge

Ingredients:

- | | |
|-------------|------|
| Mung bean | 70 g |
| Sticky rice | 70 g |
| Liliun | 10 g |

Seasoning:

- | | |
|-------|----------------------------------|
| Sugar | According to personal preference |
|-------|----------------------------------|

Cooking method:

- 1) Put the washed mung beans, sticky rice and liliun into the pan and add water until scale 1 of waterline for "PORRIDGE".
- 2) Close the outer lid and press [Porridge/Soup] button. The cooking process will end after about 1 hour and 30 minutes.
- 3) Add some sugar according to personal preference and enjoy the meal.

Cleaning and maintenance

Attentions

- Before cleaning and maintenance, please pull out the power plug first. Do not clean the rice cooker until it cools down.
- When cleaning the rice cooker, do not immerse it into water, or clean it with lacquer thinner, alcohol, cleaning powder or hard brush, etc.
- Do not use dishwasher.

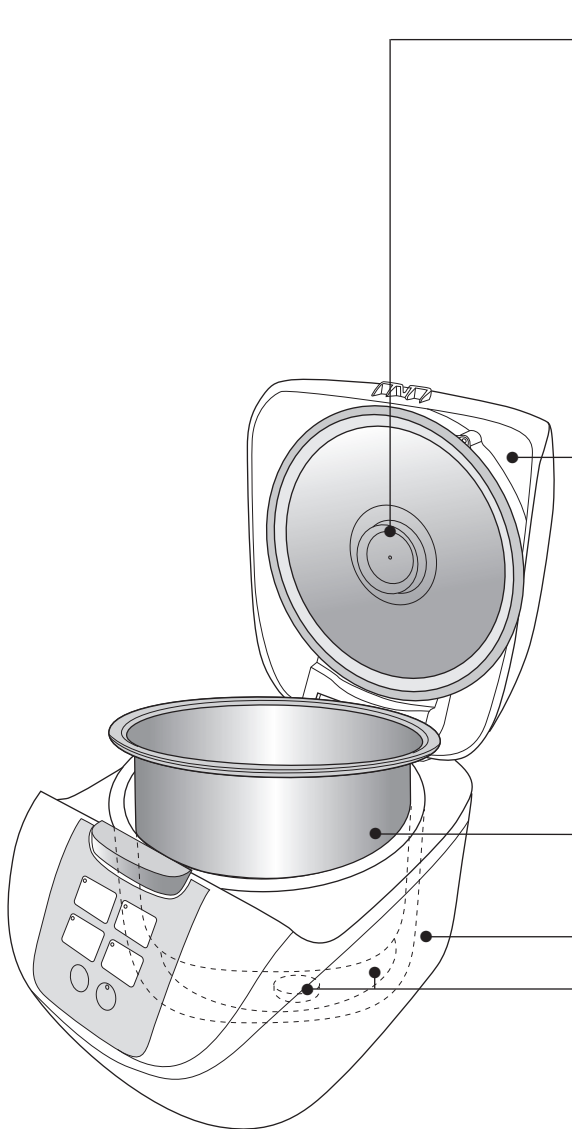

Moisturizing cap

■ Disassembling

Pull out from the heating plate.

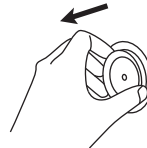

■ Assembling

Insert into the hole on the heating plate in a reverse direction as disassembly. Please fully insert it into the hole to prevent falling off.



Caution

- The moisturizing cap can be taken off directly. Clean it after each use.
- After cleaning, do not dry it with a dishwasher etc.; otherwise deformation or crack may be caused.
- When installing it after cleaning, please make sure that the seal ring has been installed on the moisturizing cap.

Entire unit • Outer lid (sealed part)

Clean with a well-wrung cloth.

- If foreign objects are not removed, the foreign objects on the heating plate may stick to it and become difficult to remove. Clean the heating plate after each use. As the metal parts are heated, there may be color change or stripes on their surfaces, which will not affect their normal functions.
- Do not pull the pan seal ring.

Pan

- Clean with diluted detergent and soft sponge. Wipe off any water on the pan.
- Color change or stripes may appear on the fluoridized coating surface, which will not affect human health or normal functions of the rice cooker.
- Depending on the frequency of use, rubbing traces may appear on the outside of the pan, which will not affect the performance of the rice cooker.

Temperature sensor • Cast heater

- When there is any foreign object adhering to such parts, gently scrub it away with fine crocus paper (#600) or a dry cloth.

Accessories

Clean with diluted detergent and soft sponge.



Rice scoop



Measuring cup

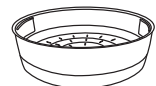

Steaming basket

Troubleshooting

Please check the following items

In the following events Items for check	Rice					Rice kept warm	Rice crust scorching	Rice kept warm	Color change	Dry	Button operations do not work	The following sounds appear during the use
	Harder	Half-cooked	Softer	Rice water overflow	Stranger smell							
• Incorrect rice quantity or water quantity	●	●	●	●							<ul style="list-style-type: none"> • The plug is pulled out or gets loose. 	<ul style="list-style-type: none"> • When there are [click] sounds in cooking, the cast heater is adjusting the temperature, this is not a malfunction. • Popping sounds during the cooking process are due to water drops on the outside of the pan turning to steam. This is not a malfunction.
• Rice is not fully washed				●		●	●					
• The pan bottom is uneven	●	●				●						
• There are foreign objects on the outside of the pan or temperature sensor	●	●	●			●	●					
• The outer lid is not correctly closed	●			●					●			
• The moisturizing cap is not correctly installed	●			●			●	●	●			
• Grease is added when cooking the rice	●	●					●					
• After cooking is finished, the rice is not loosen	●		●									
• Keep warm over 5 hours							●	●	●			
• The quantity of rice kept warm is too small	●						●	●	●			
• The rice scoop is left in the rice cooker when the rice is kept warm							●	●				
• The cold rice is kept warm							●	●	●			
• The outer lid is not firmly closed						●	●					
• The pan is not cleaned							●	●				
• While in cooking, the plug is pulled out or the [Off] button is touched		●										
• The wrong button is pressed	●	●	●	●	●							

Specifications

Model No.		SR-DF101	SR-DF181
Power/rated frequency		240 V ~ 50 Hz	
Rated power (rice cooking)		750 W	
Rated volume of pan L		3	4.8
Rice cooking volume (rice quantity) L	White Rice/Quick Cook	0.18~1.0 [1~5.5 cups]	0.18~1.8 [1~10 cups] Quick Cook [1~8 cups]
	Brown Rice	0.18~0.54 [1~3 cups]	0.18~1.08 [1~6 cups]
	Mixed rice/Glutinous rice	0.18~0.54 [1~3 cups]	0.18~0.9 [1~5 cups]
Porridge cooking volume (rice quantity) L		0.09~0.18 [1/2~1 cup]	0.09~0.36 [1/2~2 cups]
Maximum cooking volume (ingredients + water) for soup L		1.5※	2.3※
Power cord length (approx.) m		1.0	
Product weight (approx.) kg		2.5	2.8
Dimensions (approx.) cm	Width	24.5	
	Length	33.9	
	Height	19.9	24.7

- Marked with ※, it means that the maximum cooking volume for soup is the highest waterline for "PORRIDGE".
- For power cord replacement and product repairing, please contact an authorized service center of Panasonic.
- The design and specifications are intended to change without prior notice.

Panasonic Home Appliances Rice Cooker (Hangzhou) Co., Ltd.
Website: <http://panasonic.net>

RZ19BE56
S1211-0
Printed in China

Panasonic Warranty

Home Appliance 12 Month Warranty from Date of Purchase

1. Subject to the conditions of this warranty Panasonic or its Authorised Service Centre will perform necessary service on the product without charge for parts or labour, if in the opinion of Panasonic, the product is found to be faulty within the warranty period. For Line Communications products (i.e. Cordless Phones, etc) the genuine battery(s) has a 3 month warranty.
2. This warranty only applies to Panasonic products purchased in Australia and sold by Panasonic Australia or its Authorised Distributors or Dealers and only where the products are used and serviced within Australia or its territories. Warranty cover only applies to service carried out by a Panasonic Authorised Service Centre and only if valid proof of purchase is presented when warranty service is requested.
3. This warranty only applies if the product has been installed and used in accordance with the manufacturer's recommendations (as noted in the operating instructions) under normal use and reasonable care (in the opinion of Panasonic). The warranty covers normal domestic use only (also Clip & Trim Professional use) and does not cover damage, malfunction or failure resulting from use of incorrect voltages, incorrect installation, accident, misuse, neglect, build-up of dirt or dust, abuse, maladjustment of customer controls, mains supply problems, thunderstorm activity, infestation by insects or vermin, tampering or repair by unauthorised persons (including unauthorised alterations), exposure to abnormally corrosive conditions or any foreign object or matter having entered the product.
4. This warranty does not cover the following items unless the fault or defect existed at the time of purchase:
 - (a) Cabinet Parts
 - (b) Microwave Oven cook plates.
 - (c) User replaceable Batteries
 - (d) Kneader mounting shaft unit and Heads, Cutters, Foils, Blades and other accessories.(e) Noise or vibration that is considered normal
5. To claim warranty service, when required, you should:
 - Telephone Panasonic's Customer Care Centre on 132600 or visit our website referred to below and use the Service Centre Locator for the name/address of the nearest Authorised Service Centre.
 - Send or take the product to a Panasonic Authorised Service Centre together with your proof of purchase receipt as a proof of purchase date. Please note that freight and insurance to and / or from your nearest Authorised Service Centre must be arranged by you.
6. The warranties hereby conferred do not extend to, and exclude, any costs associated with the installation, de-installation or re-installation of a product, including costs related to the mounting, de-mounting or remounting of any screen, (and any other ancillary activities), delivery, handling, freighting, transportation or insurance of the product or any part thereof or replacement of and do not extend to, and exclude, any damage or loss occurring by reason of, during, associated with, or related to such installation, de-installation, re-installation or transit.

Panasonic Authorised Service Centres are located in major metropolitan areas and most regional centres of Australia, however, coverage will vary dependant on product. For advice on exact Authorised Service Centre locations for your product, please telephone our Customer Care Centre on 132600 or visit our website and use the Service Centre Locator.

In addition to your rights under this warranty, Panasonic products come with consumer guarantees that cannot be excluded under the Australian Consumer Law. If there is a major failure with the product, you can reject the product and elect to have a refund or to have the product replaced or if you wish you may elect to keep the goods and be compensated for the drop in value of the goods. You are also entitled to have the product repaired or replaced if the product fails to be of acceptable quality and the failure does not amount to a major failure.

If there is a major failure in regard to the product which cannot be remedied then you must notify us within a reasonable period by contacting the Panasonic Customer Care Centre. If the failure in the product is not a major failure then Panasonic may choose to repair or replace the product and will do so in a reasonable period of time from receiving notice from you.

THIS WARRANTY CARD AND THE PURCHASE DOCKET (OR SIMILAR PROOF OF PURCHASE) SHOULD BE RETAINED BY THE CUSTOMER AT ALL TIMES

If you require assistance regarding warranty conditions or any other enquiries, please visit the **Panasonic Australia** website **www.panasonic.com.au** or contact by phone on **132 600**
If phoning in, please ensure you have your operating instructions available.

Panasonic Australia Pty. Limited

ACN 001 592 187 ABN 83 001 592 187

1 Innovation Road, Macquarie Park NSW 2113
www.panasonic.com.au

Panasonic Warranty

Home Appliance 12 Month Warranty from Date of Purchase

1. Subject to the conditions of this warranty Panasonic or its Authorised Service Centre will perform necessary service on the product without charge for parts or labour, if in the opinion of Panasonic, the product is found to be faulty within the warranty period. For Line Communications products (i.e. Cordless Phones, etc) the genuine battery(s) has a 3 month warranty.
2. This warranty only applies to Panasonic products purchased in New Zealand and sold by Panasonic New Zealand or its Authorised Distributors or Dealers and only where the products are used and serviced within New Zealand or its territories. Warranty cover only applies to service carried out by a Panasonic Authorised Service Centre and only if valid proof of purchase is presented when warranty service is requested.
3. This warranty only applies if the product has been installed and used in accordance with the manufacturer's recommendations (as noted in the operating instructions) under normal use and reasonable care (in the opinion of Panasonic). The warranty covers normal domestic use only (also Clip & Trim Professional use) and does not cover damage, malfunction or failure resulting from use of incorrect voltages, incorrect installation, accident, misuse, neglect, build-up of dirt or dust, abuse, maladjustment of customer controls, mains supply problems, thunderstorm activity, infestation by insects or vermin, tampering or repair by unauthorised persons (including unauthorised alterations), exposure to abnormally corrosive conditions or any foreign object or matter having entered the product.
4. This warranty does not cover the following items unless the fault or defect existed at the time of purchase:
 - (a) Cabinet Parts
 - (b) Microwave Oven cook plates.
 - (c) User replaceable Batteries
 - (d) Kneader mounting shaft unit and Heads, Cutters, Foils, Blades and other accessories.
 - (e) Noise or vibration that is considered normal
5. To claim warranty service, when required, you should:
 - Telephone Panasonic's Customer Care Centre on 09 2720178 or visit our website referred to below and use the Service Centre Locator for the name/address of the nearest Authorised Service Centre.
 - Send or take the product to a Panasonic Authorised Service Centre together with your proof of purchase receipt as a proof of purchase date. Please note that freight and insurance to and / or from your nearest Authorised Service Centre must be arranged by you.
6. The warranties hereby conferred do not extend to, and exclude, any costs associated with the installation, de-installation or re-installation of a product, including costs related to the mounting, de-mounting or remounting of any screen, (and any other ancillary activities), delivery, handling, freighting, transportation or insurance of the product or any part thereof or replacement of and do not extend to, and exclude, any damage or loss occurring by reason of, during, associated with, or related to such installation, de-installation, re-installation or transit.

Panasonic Authorised Service Centres are located in major metropolitan areas and most regional centres of New Zealand, however, coverage will vary dependant on product. For advice on exact Authorised Service Centre locations for your product, please telephone our Customer Care Centre on 09 2720178 or visit our website and use the Service Centre Locator.

Unless otherwise specified to the consumer the benefits conferred by this express warranty are additional to all other conditions, warranties, guarantees, rights and remedies expressed or implied by the Consumer Guarantees Act of New Zealand and all other obligations and liabilities on the part of the manufacturer or supplier and nothing contained herein shall restrict or modify such rights, remedies, obligations and liabilities.

THIS WARRANTY CARD AND THE PURCHASE DOCKET (OR SIMILAR PROOF OF PURCHASE) SHOULD BE RETAINED BY THE CUSTOMER AT ALL TIMES

If you require assistance regarding warranty conditions or any other enquiries, please visit the **Panasonic New Zealand** website **www.panasonic.co.nz** or contact by phone on **09 2720178**
If phoning in, please ensure you have your operating instructions available.

Panasonic New Zealand Customer Care Centre

Phone: 09 2720178

Fax: 09 2720129

Email: customerservice@nz.panasonic.com

Website: www.panasonic.co.nz/support